

SCATOLE PER POMPE OLEODINAMICHE GEARBOX FOR HYDRAULIC GEAR PUMPS GETRIEBE FÜR ÖLKRAFTZAHNRADERPUMPEN

MP21

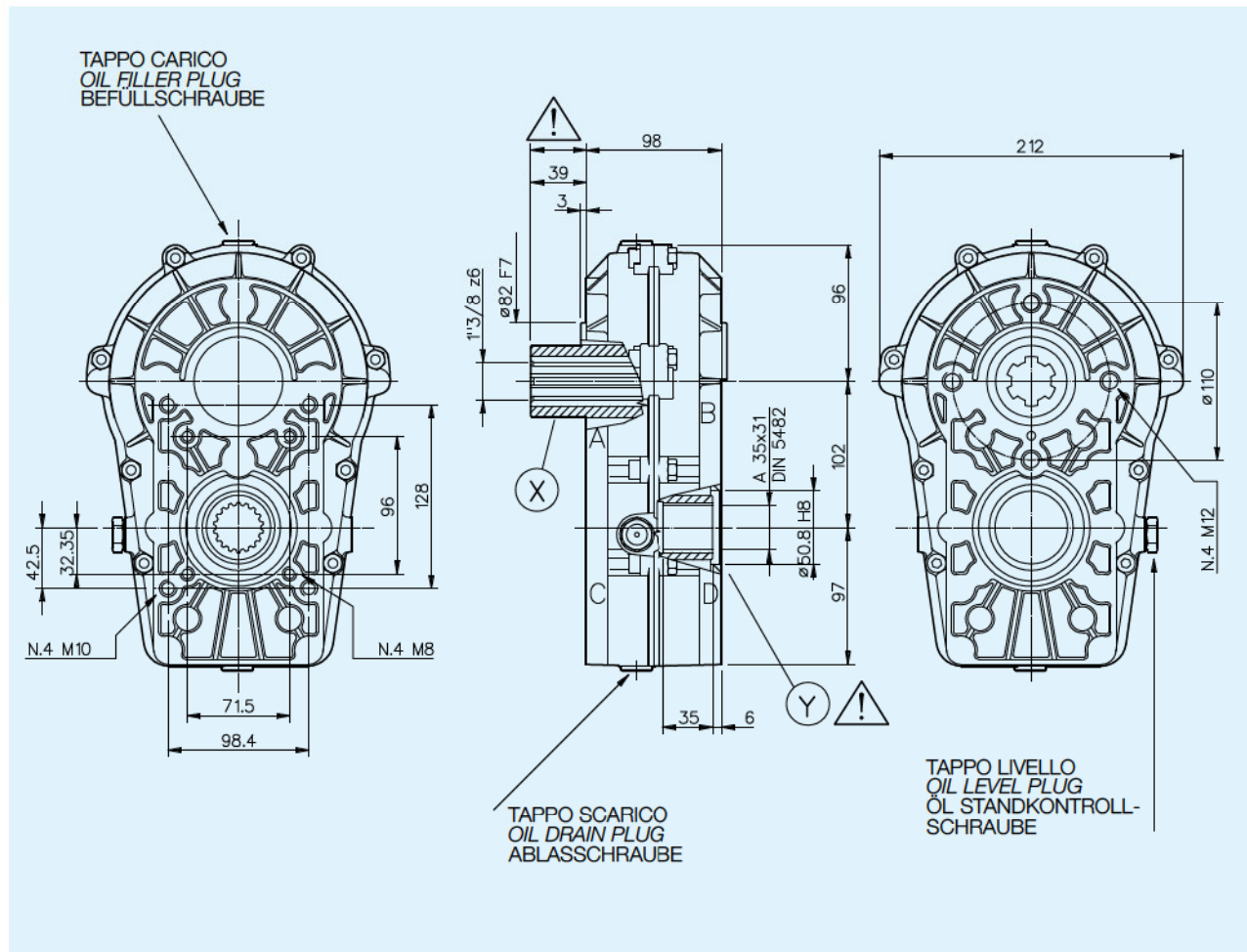

| RAPPORTO RATIO VERHÄLTNIS | INGRESSO INPUT EINGANG | | | USCITA OUTPUT AUSGANG | | MONTAGGIO ARRANGEMENT MONTAGE | ENTRATA INPUT EINGANG | CODICE CODE BESTELLNUMMER |
|---------------------------------|------------------------------|------------------------------------|----------------------------------|-----------------------------------|-------------------|-------------------------------------|-----------------------------|---------------------------------|
| | min ⁻¹ | POTENZA POWER LEISTUNG CV | COPPIA TORQUE DREHM. kW | COPPIA TORQUE DREHM. N·m | min ⁻¹ | | | |
| 1:2 | 540 | 32 | 23.5 | 425 | 217 | 1080 | X | 6073.300.020 |
| 1:3,35 | 540 | 35 | 25.7 | 460 | 135 | 1809 | X | 6073.300.033 |
| 1:3,8 | 540 | 31 | 22.8 | 404 | 108 | 2057 | X | 6073.300.038 |

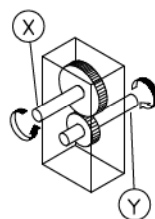

| PESO INDICATIVO APPROXIMATE WEIGHT GEWICHT CA. | OLIO CONSIGLIATO RECOMMENDED OIL EMPFOHLENES ÖL | MATERIALI MATERIALS WERKSTOFF | | | CUSCINETTI BEARINGS NADELLAGER | | | | |
|--|---|-------------------------------------|----------------------------|-----------------------------------|--------------------------------------|------|------|------|---|
| | | SCATOLA CASE GEHAUSE | ALBERI SHAFTS WELLEN | INGRANAGGI GEARS VERZÄHNUNG | A | B | C | D | E |
| Kg. | SAE 90 Kg. | | | | | | | | |
| 9 | 0,46 | GDAISi 12 | 20MnCr5 | 20MnCr5 | 6010 | 6010 | 6009 | 6009 | |