



CYCLONE[™] HYDRAULICS

Engineering Data

20 GPM Cyclone

The Cyclone Reservoir is designed to rapidly remove entrained air from hydraulic fluid. As the name implies, it efficiently accomplishes this task by way of well-known cyclonic action. As fluid is returned to the reservoir it is forced to revolve at a very high rate of speed. The heavier, non-aerated fluid is forced to the outside wall of the reservoir interior whereby it is available at the pump inlet port. The lighter air bubbles migrate to the center of the reservoir and are dissipated through the filler/breather cap.

Being far more efficient at removing entrained air than a conventional hydraulic reservoir, the Cyclone dramatically reduces the volume of fluid required to be stored within the reservoir. Reductions in reservoir size and installed weight of up to 90 percent are possible as compared to traditional reservoirs.

20 GPM Nylon

Construction - high strength nylon

Diameter - 8.9 In. (226 mm)

Height - 15.5 In. (394 mm)

Space Claim - 0.75 Cu. Ft. (21 liter)

Maximum Flow Rate - 20 GPM (75.7 lpm)

Minimum Flow Rate - 10 GPM (37.9 lpm) to insure adequate cyclonic action

Suction Head @ Max Flow - 0.25 PSI (1.72 kPa)

Makeup Volume - 0.62 GAL (2.38 liter)

Total Volume - 2.00 GAL (7.57 liter)

Dry Weight - 9.64 Lbs. (4.37 kg)

Maximum Ambient Temperature - 220° F (104° C)

Maximum Pressure Capability - 5 PSIG (0.35 Bar)

Gradability - 60% Grade (31° angle)

Filtration - the Cyclone Reservoir makes no claim to filter contaminants from the fluid. This task must be performed by way of external pressure or return line filtration.

Heat Exchangers - the Cyclone Reservoir makes no claim to remove heat from the fluid. This task must be performed by way of external return line heat exchange equipment.

Fluid Compatibility - the Cyclone Reservoir is compatible with most traditional hydraulic fluids.

Level Switch - 12 or 24 Vdc, normally open when level is low. Max current equals 1.0 Amp. Connector is Deutsch DT04-2P.

Installation - it is recommended that each connection hose be clamped to the machine within 12" or the reservoir.

Engineering Data



20 GPM Steel

Construction - powder coated steel

Diameter - 8.50 In. (216 mm)

Height - 15 In. (381 mm)

Space Claim - 0.5 Cu. Ft. (14 liter)

Maximum Flow Rate - 20 GPM (75.7 lpm)

Minimum Flow Rate - 10 GPM (37.9 lpm) to insure adequate cyclonic action

Suction Head @ Max Flow - 0.25 PSI (1.72 kPa)

Makeup Volume - 0.7 GAL (2.65 liter)

Total Volume- 2.00 GAL (7.6 liter)

Dry Weight - 19.1 Lbs. (8.66 kg)

Maximum Ambient Temperature - 220° F (104° C)

Maximum Pressure Capability - 5 PSIG (0.35 Bar)

Gradability - 60% Grade (31° angle)

Filtration - the Cyclone Reservoir makes no claim to filter contaminants from the fluid. This task must be performed by way of external pressure or return line filtration.

Heat Exchangers - the Cyclone Reservoir makes no claim to remove heat from the fluid. This task must be performed by way of external return line heat exchange equipment.

Fluid Compatibility - the Cyclone Reservoir is compatible with most traditional hydraulic fluids.

Level Switch - 12 or 24 Vdc, normally open when level is low. Max current equals 1.0 Amp. Connector is Deutsch DT04-2P.

Installation - it is recommended that each connection hose be clamped to the machine within 12" or the reservoir.

Dimensional Data

20 GPM Nylon

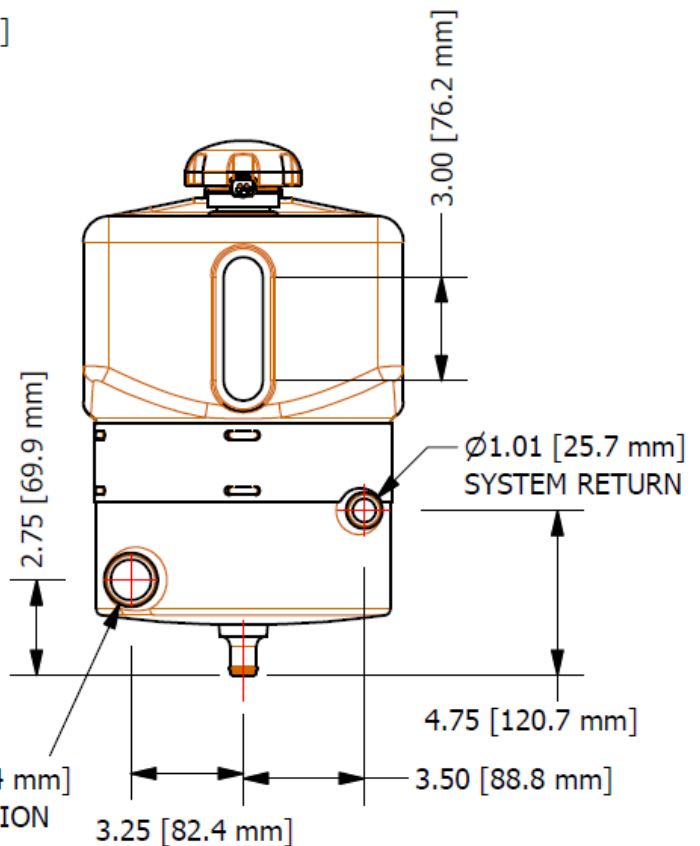
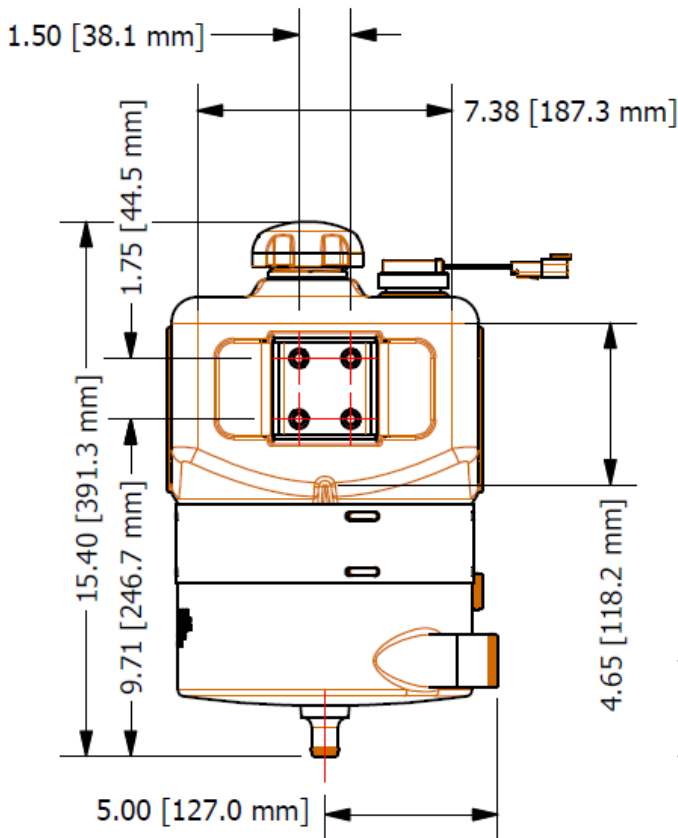
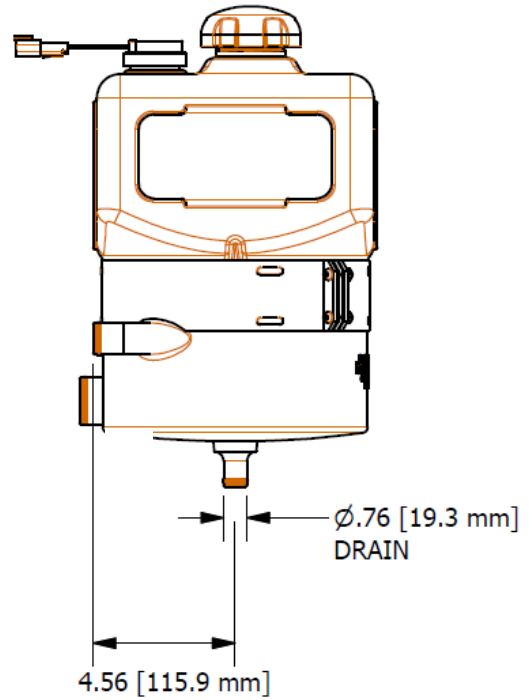
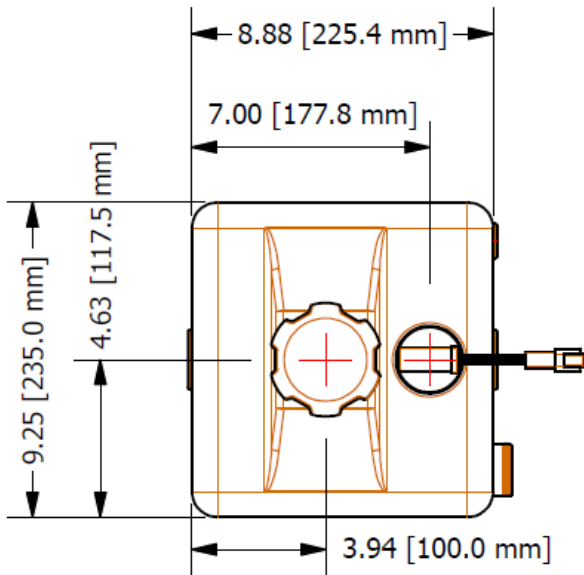

Ø1.51 [38.4 mm]
PUMP SUCTION

Mounting Options

20 GPM Nylon

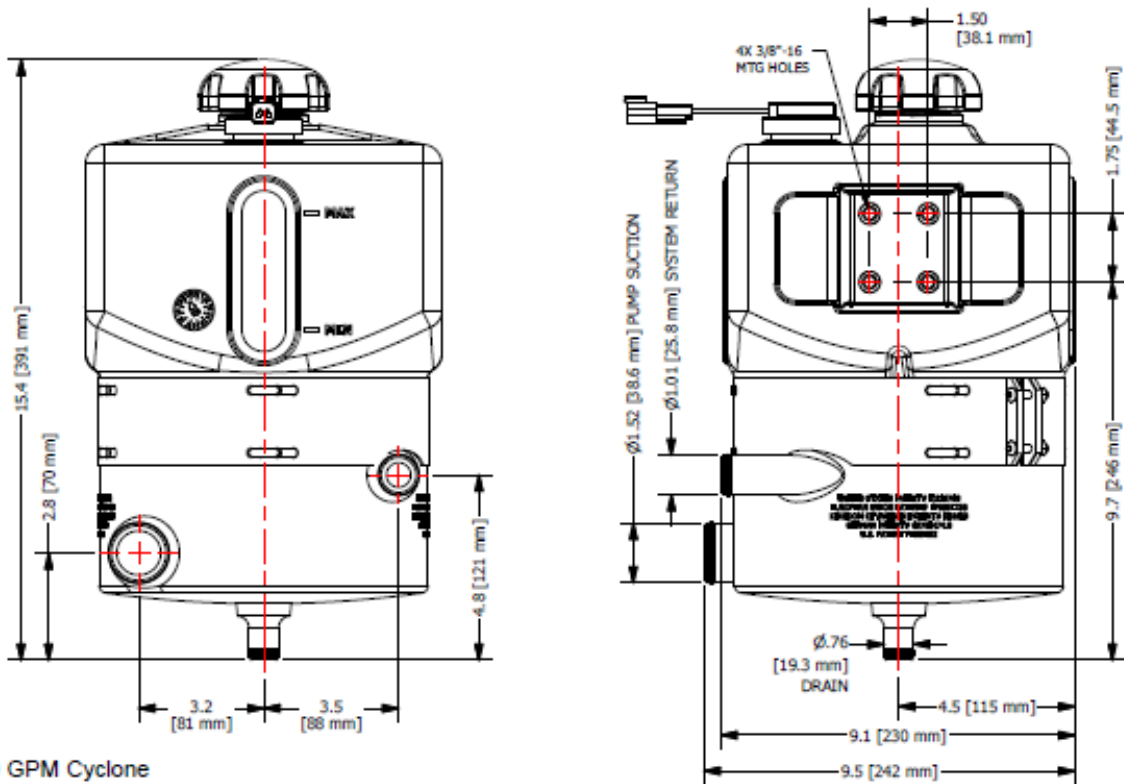
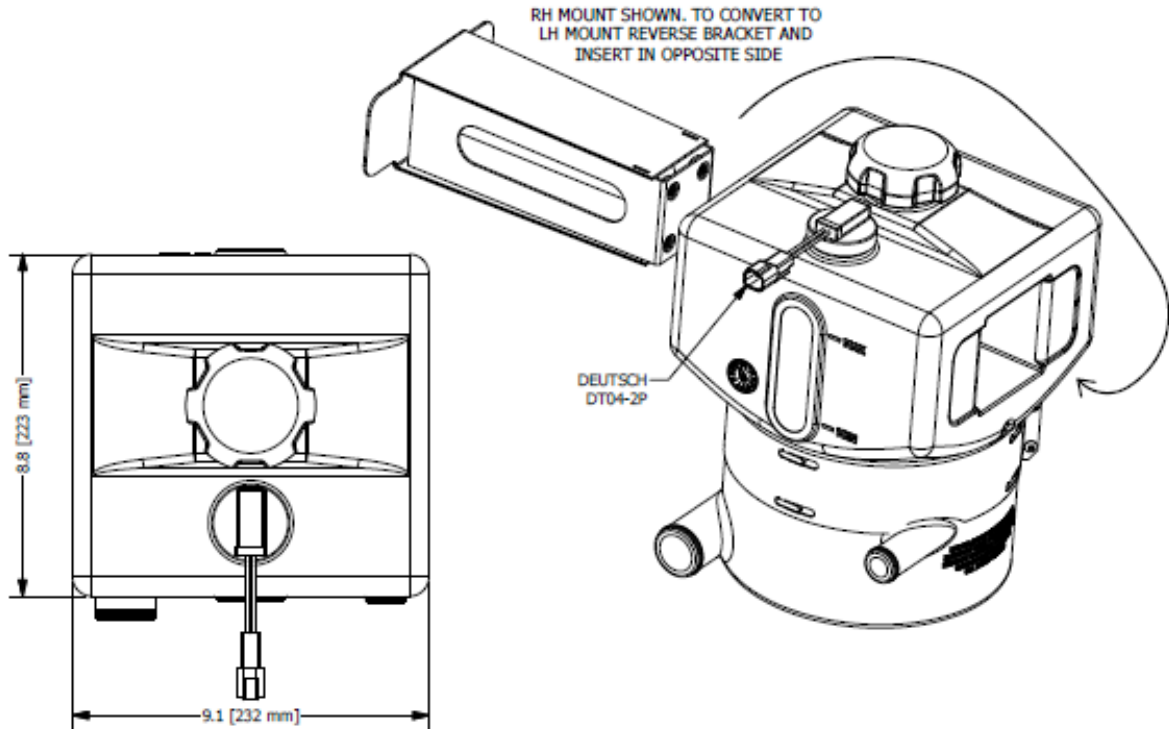

Dimensional Data

20 GPM Steel

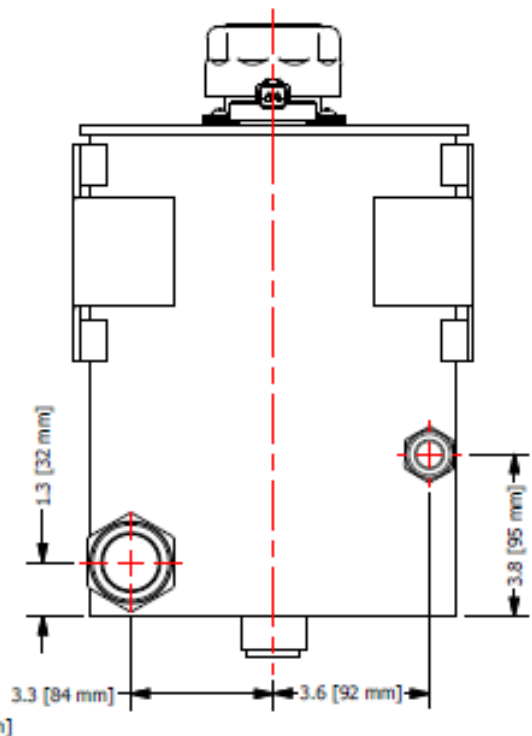
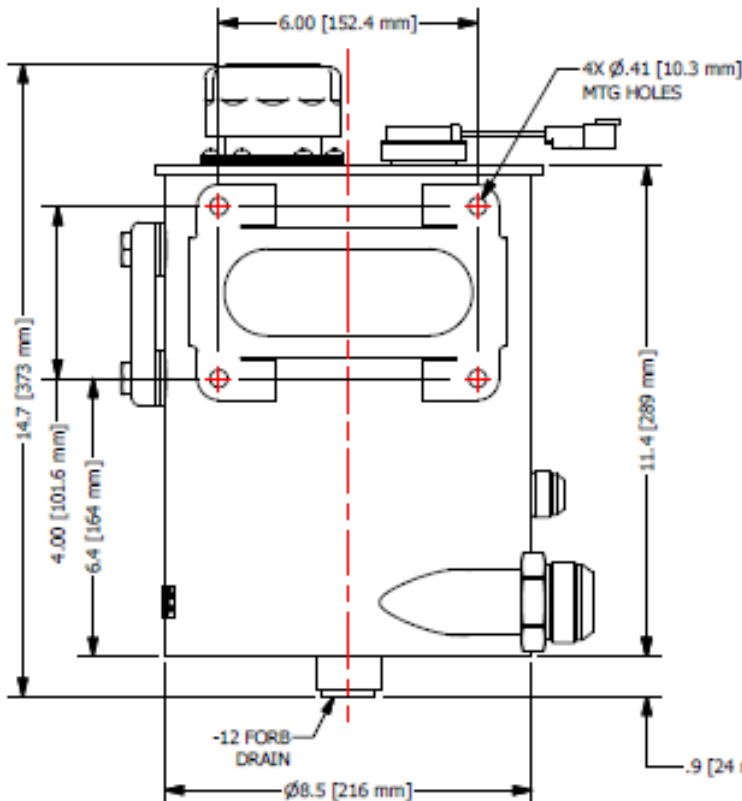
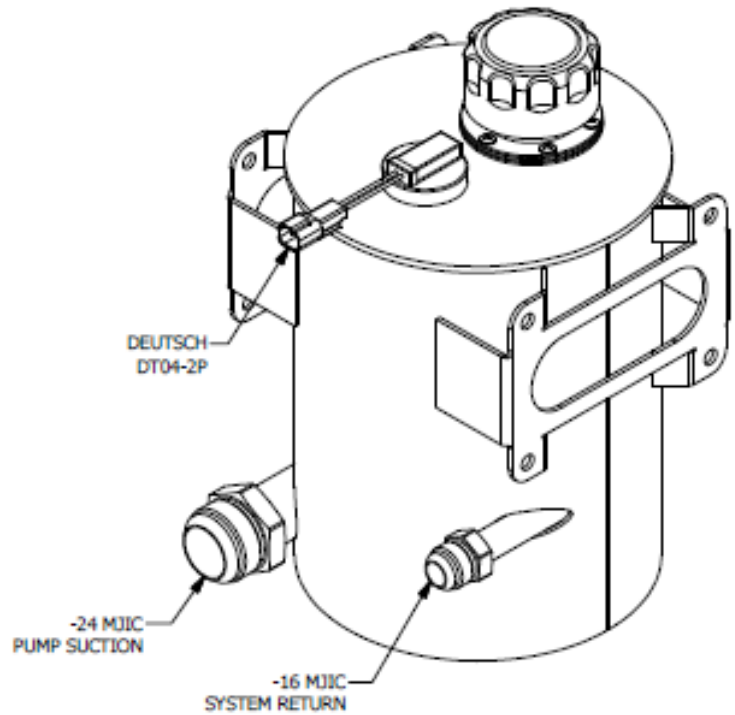
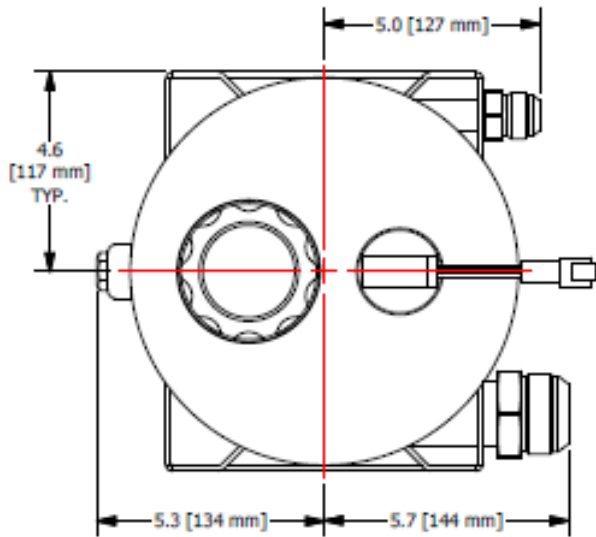

How to order

20 GPM Nylon or Steel

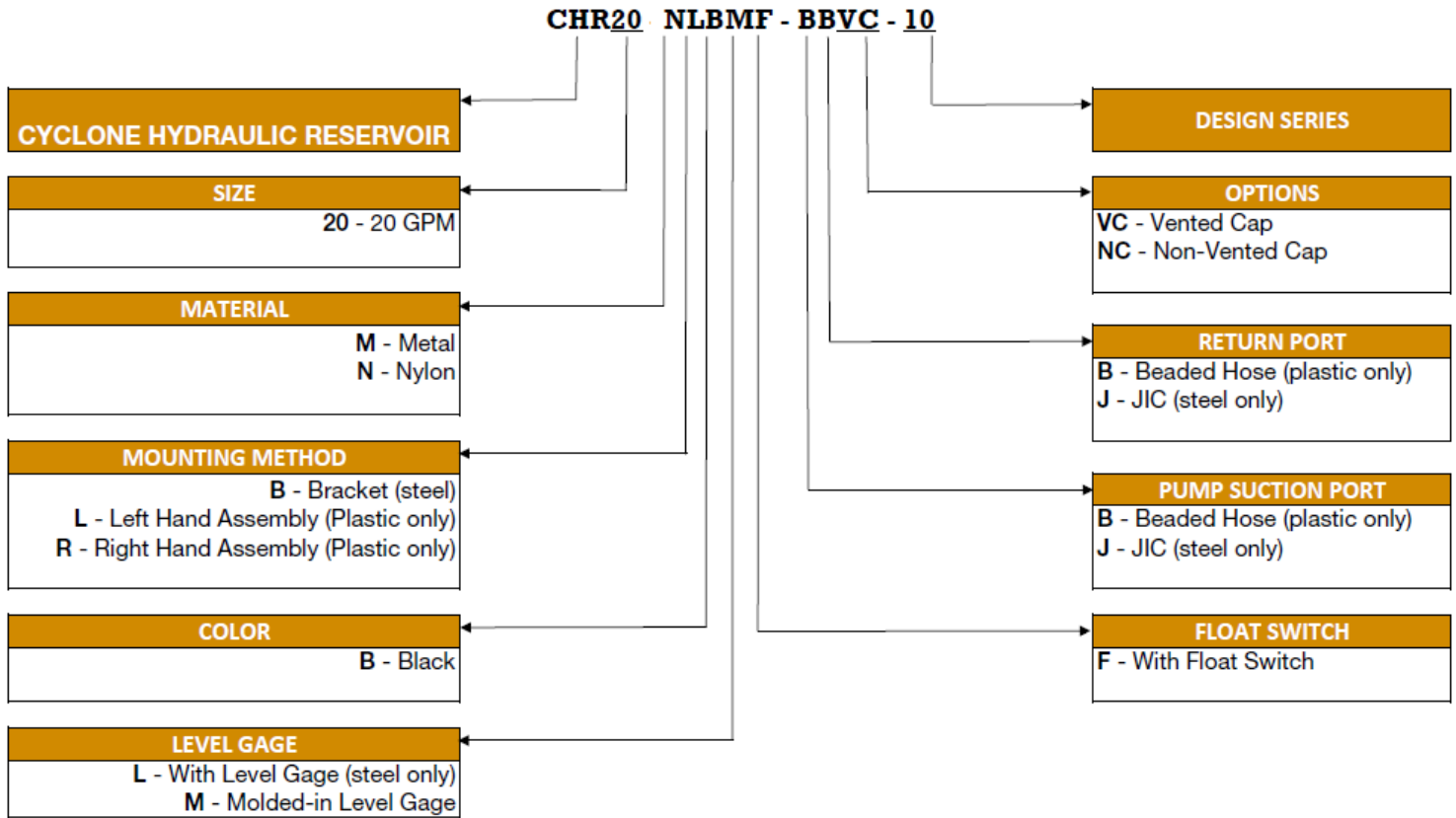

Additional Items

As a best practice we recommend utilizing Aeroquip hydraulic hoses and clamps for the Cyclone Hydraulic Reservoir. Below are the corresponding part numbers for both the 20 GPM Nylon and Steel Cyclones.

RESERVOIR	PORT	HOSE	HOSE CLAMP
CHR-20-N	Suction	FC619-24	HC-150
	Return	H20116BK-250R	HC-100
	Drain	H20112BK-250R	600-010
CHR-20-M	Suction	#24 Male JIC	Not Applicable
	Return	#16 Male JIC	Not Applicable
	Drain	1.062-12 SAE Female	Not Applicable

Contact

262.709.7400

info@cyclonehydraulics.com